

Calderines de acero Réservoirs en acier

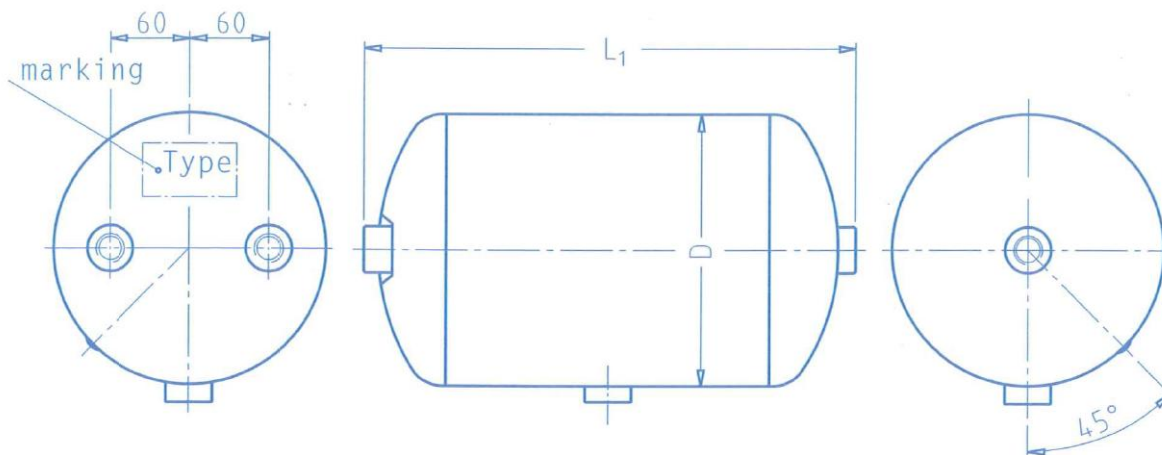

- Temperature range
-40°C - +100°C
- Max. working pressure :
PS 12,5 bar
- CE-symbol an EN 286-2
- All threaded boss
connections : M22 x 1,5 in
acc. With DIN ISO
- Dimensions in acc. With DIN 74 281
- Minimized weights
- Colour : black base coat RAL 9005

REFERENCIA	CAPACIDAD (L)	D (mm)	L1 (mm)	PESO (kg)	PACKAGING PALET DE MADERA 1000x1200 mm
111482	10	206	370	4,8	48
111483	15	206	530	6,4	64
112481	20	206	690	8,2	64
112482	20	246	500	7,3	56
112485	20	276	416	7	72
112487	25	246	610	8,7	56
112483	30	246	720	10	56
112486	30	276	585	9,4	48
112484	37	246	869	11,9	28
113481	40	246	940	12,8	28
114481	60	246	1369	18,1	28
111482	60	276	1110	16,7	24
111484	60	396	580	16,8	24
115481	80	396	750	21,1	24
115482	85	276	1543	23,8	24
116481	100	396	915	25,4	12
117481	120	396	1089	29,9	12
117482	160	396	1423	38,5	12

Calderines de acero
Réservoirs en acier

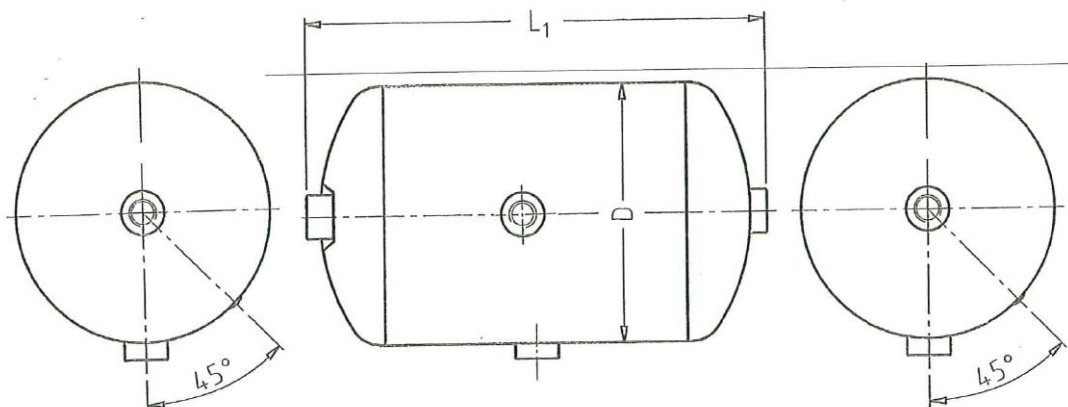

- Temperature range
-40°C - +100°C
- Max. working pressure :
PS 12,5 bar
- CE-symbol an EN 286-2
- All threaded boss
connections : M22 x 1,5 in
acc. With DIN ISO
- Dimensions in acc. With DIN 74 281
- Minimized weigths
- Colour : black base coat RAL 9005

REFERENCIA	CAPACIDAD (L)	D (mm)	L1 (mm)	PESO (kg)	PACKAGING PALET DE MADERA 1000x1200 mm
113482	40	276	760	11,8	48
113483	40	310	620	11,3	48
114483	60	310	895	15,6	24

Calderines de aluminio
Réservoirs en aluminium

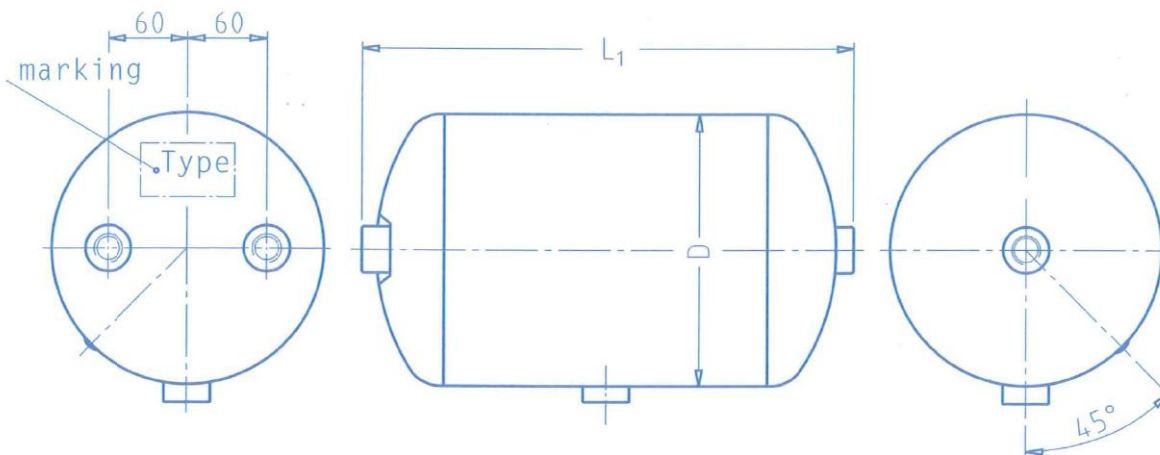

- Temperature range
-40°C - +100°C
- Max. working pressure :
Up to 276mm - 12,5 bar
From 310mm – 11 bar
- CE-symbol an EN 286-2
- Dimensions in acc. With DIN 74 281
- All threaded boss connections :
M22 x 1,5 in acc. With DIN ISO
- Without surface treatment

REFERENCIA	CAPACIDAD (L)	D (mm)	L1 (mm)	PESO (kg)	PACKAGING PALET DE MADERA 1000x1200 mm
131403	10	206	375	2,3	48
131404	15	206	535	3,1	64
132404	20	206	695	4,0	64
132405	20	246	505	3,5	56
132406	20	276	415	3,3	72
132407	30	246	724	4,9	56
132408	30	276	590	4,5	48
132409	37	246	880	5,9	28
133402	40	246	945	6,2	28
133403	40	276	766	5,8	48
133404	40	310	620	5,5	48
134401	60	246	1390	9,0	28
134402	60	276	1115	8,2	24
134403	60	310	900	7,7	24
134404	60	396	585	7,4	24
135401	80	396	755	9,3	24
136401	100	396	920	10,8	12
137401	120	396	1094	13,0	12

SCHULZ IBERICA, S.A.
TECNICA DE VEHICULOS Y CONTAINER

Calderines de aluminio
Réservoirs en aluminium

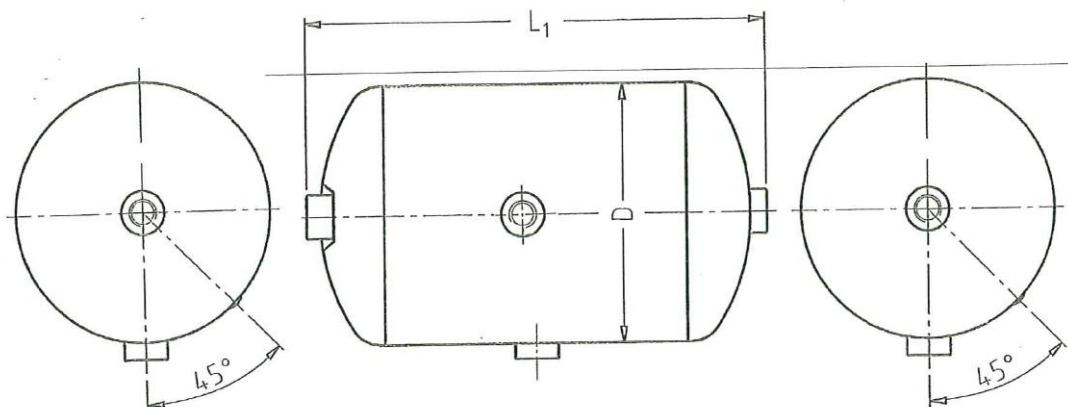

- *Temperature range*
-40°C - +100°C
- *Max. working pressure :*
Up to 276mm - 12,5 bar
From 310mm – 11 bar
- *CE-symbol an EN 286-2*
- *Dimensions in acc. With DIN*
74 281
- *All threaded boss connections :*
M22 x 1,5 in acc. With DIN ISO
- *Without surface treatment*

REFERENCIA	CAPACIDAD (L)	D (mm)	L1 (mm)	PESO (kg)	PACKAGING PALET DE MADERA 1000x1200 mm
133434	40	310	620	5,5	48
134417	60	310	900	7,7	24