

Elevador Bilateral para Vehículos Mega

Relevage bilatéral pour Véhicules Mega

ELEVADOR DE EJE COMPUESTO POR DOS
 MODULOS BILATERALES
 ADAPTABLE A VEHICULOS CON SUSPENSION
 NEUMATICA
 ESPECIAL VEHICULOS MEGA –ALTIMA REDUCIDA
 FACIL MONTAJE. SIN DESMONTAR EL BULON DE LA
 SUSPENSION

*RELEVAGE D'ESSIEU COMPOSE DE DEUX
 MODULES BILATÉRALES
 ADAPTABLE AUX VEHICULES AVEC SUSPENSION
 PNEUMATIQUE
 SPECIAL VEHICULES MEGA – HAUTEUR REDUITE
 MONTAGE FACILE. SANS DEMONTER L'AXE DE LA
 SUSPENSION*

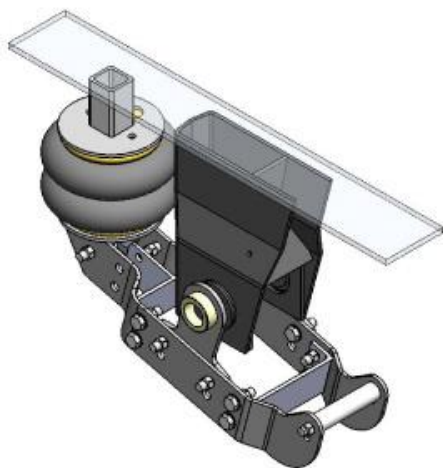
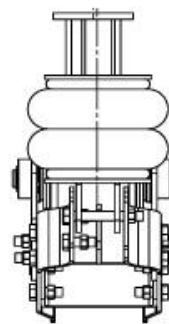
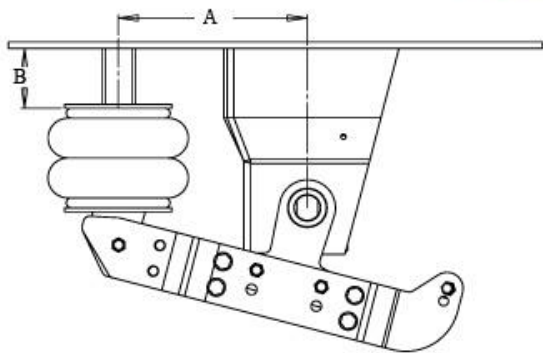

SCHULZ IBERICA, S.A.
 TECNICA DE VEHICULOS Y CONTAINER

REF. SCHULZ	MODELO ELEVADOR MODÈLE RELEVAGE	ADAPTABLE A SUSPENSIÓN ADAPTABLE AU SUSPENSION
765.000.000	BILATERAL MEGA M00-W	WW MEGA
765.000.040	BILATERAL MEGA M40-S	SF MEGA
765.000.050	BILATERAL MEGA M50-B	BP MEGA
765.000.051	BILATERAL MEGA M51-B	BP 70 MEGA
765.000.060	BILATERAL MEGA M60-R	RR FL11000 MEGA
765.000.075	BILATERALMEGA M75-SM	SMRO D/M

*OTROS MODELOS, CONSULTAR CON EL DPTO. TECNICO DE SCHULZ IBERICA.